

THIS DRAWING IS UNPUBLISHED. RELEASED FOR PUBLICATION
© COPYRIGHT BY TYCO ELECTRONICS CORPORATION. ALL RIGHTS RESERVED.

LOC		DIST		REVISIONS			
P	LTR	DESCRIPTION	DATE	DWN	APVD		
AF	50	AE	REV PER 0G3A-0064-05	28JAN05	JR	GP	

SUGGESTED MATING TAB

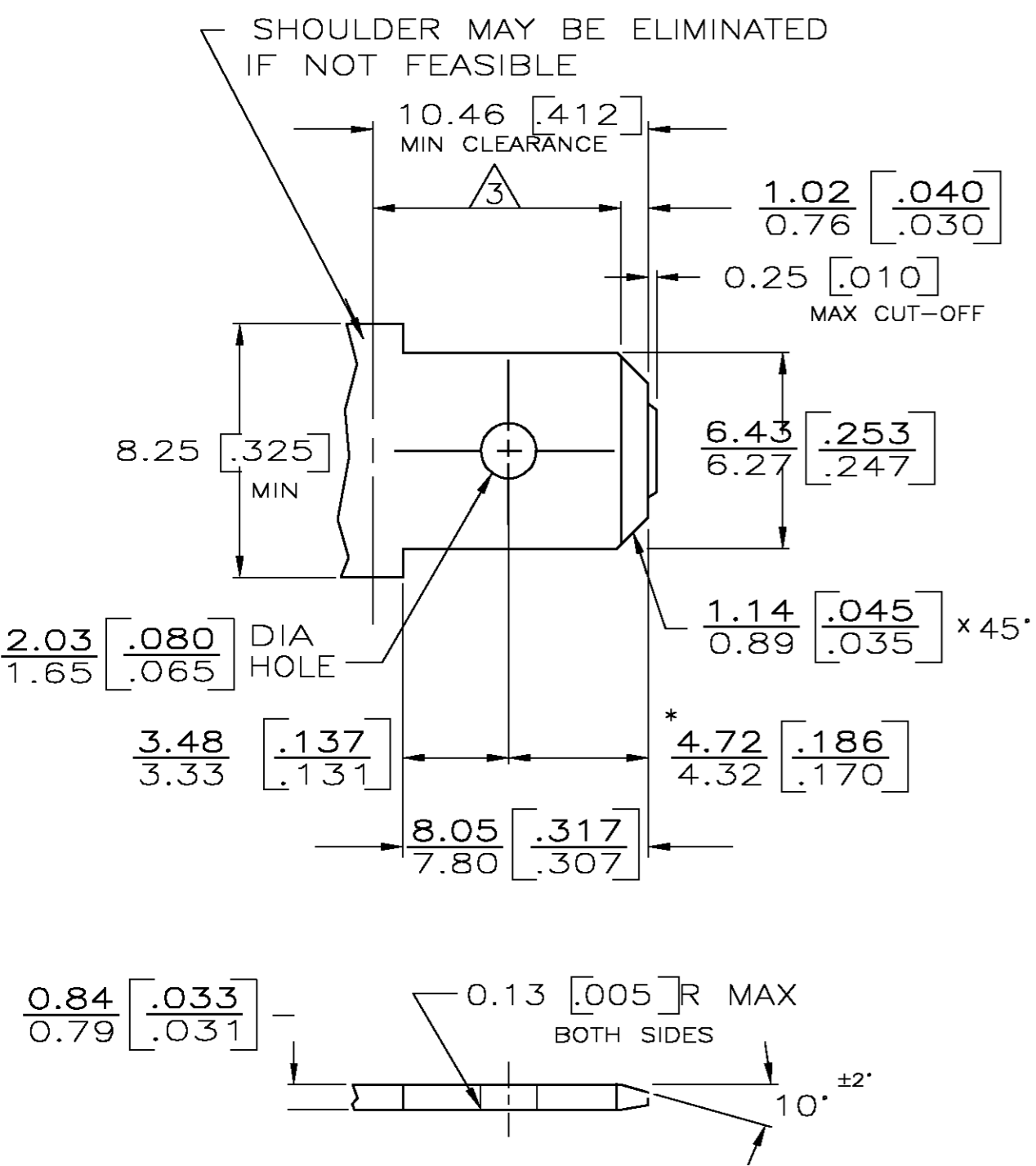

- 1 - MATL: 1/2H BRASS OR NICKEL PL STEEL.
 - 2 - NO BURRS PERMISSIBLE AT HOLE.
 - 3 - MUST BE FLAT WITHIN 0.076 [.003] OVER THIS LENGTH.
 - 4 - TIN PLATING IS REQUIRED ON BRASS WHEN TERMINAL TEMP. IS OVER 225°F.
 - 5 - HOLE MUST BE SYMMETRICAL ABOUT TAB ϕ WITHIN 0.076 [.003]
- * TO BE USED ONLY WHEN SHOULDER IS ELIMINATED.

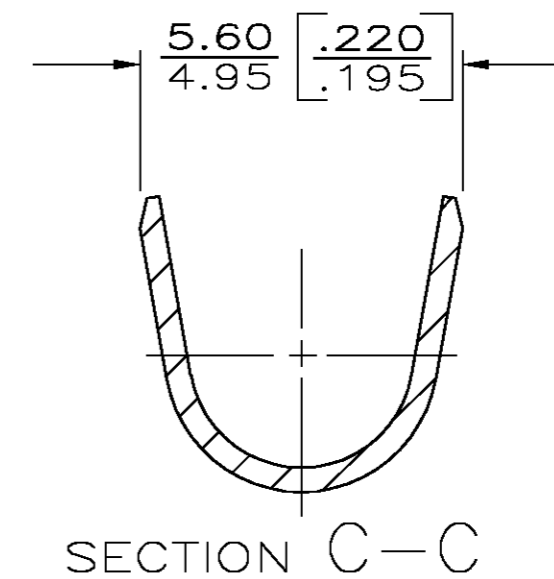
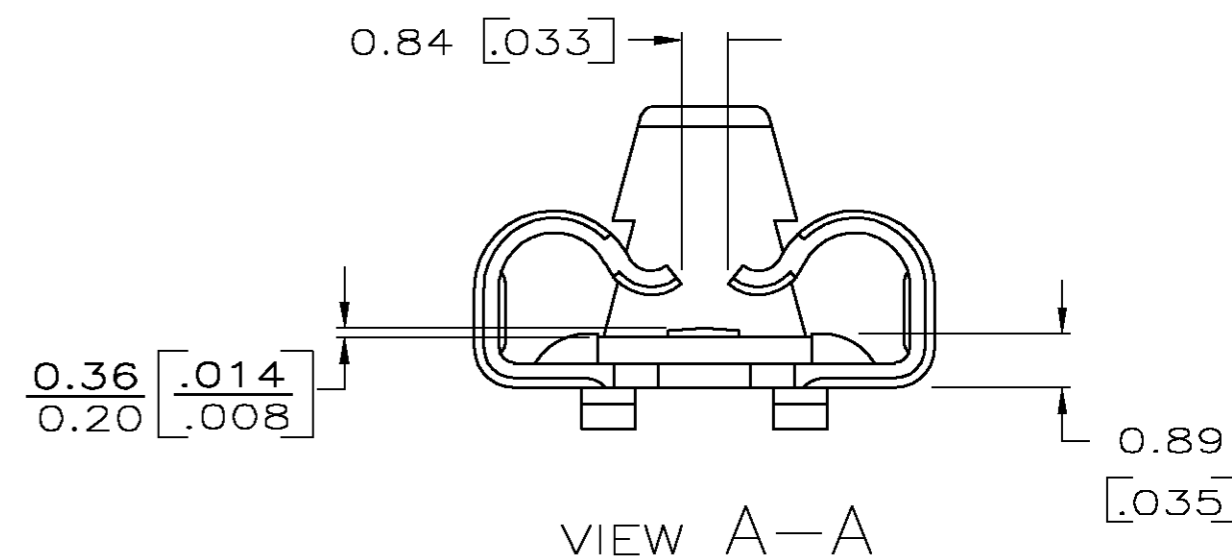
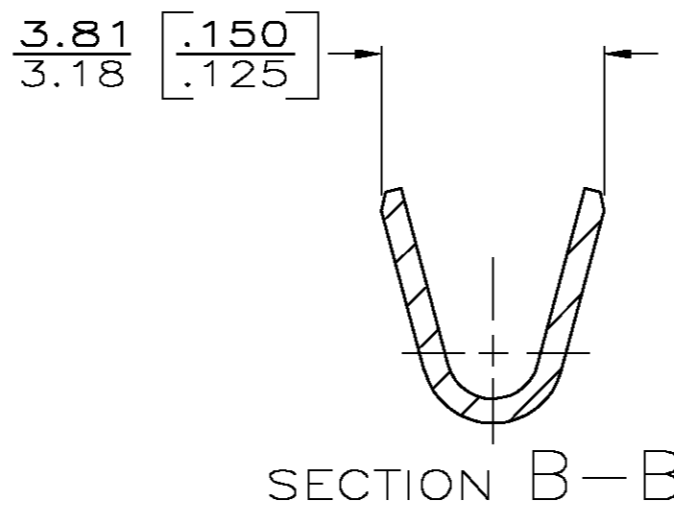
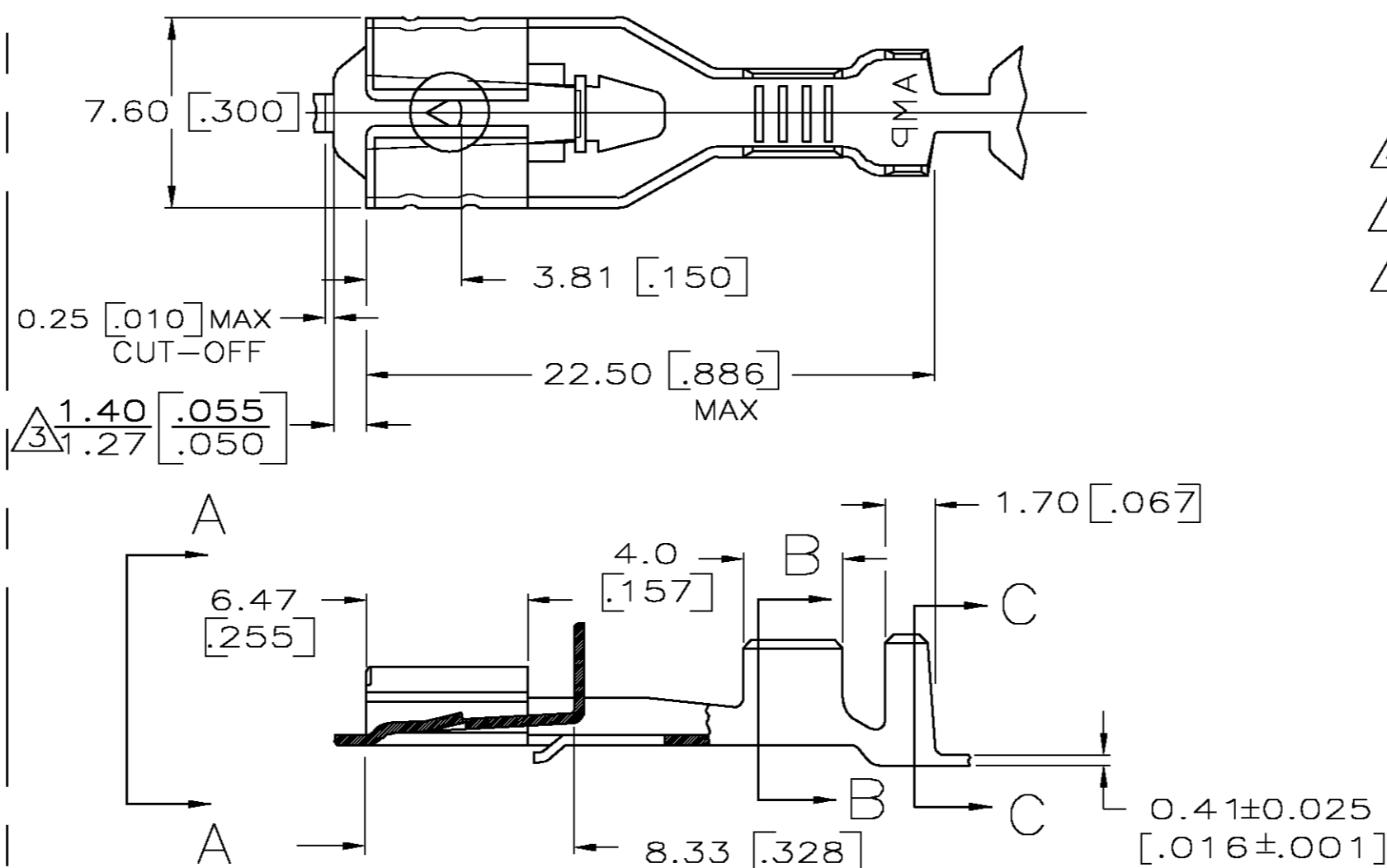

- 1 DIMENSIONS IN BRACKETS ARE IN INCHES.
- 2 PRODUCT PROVIDED IN STRIP FORM, BREAKS MAY BE PRESENT.
- 3 THE 1.40 [.055] / 1.27 [.050] DIMENSION MUST BE MAINTAINED BY THE APPLICATOR CUT-OFF TO ENSURE THE PROPER LOCKING FUNCTION OF THE RECEPTACLE.
- 4 LUBRICANT APPLIED AFTER TIN PLATING
- 5 STRESS RELIEVED
- 6 PRELIMINARY - NOT FOR PRODUCTION

PRE-TIN	2.29-3.94 [.090-.155] DIA	[#18-#14] AWG	63097-5
TIN 0.002032 [.000080] MIN	2.29-3.94 [.090-.155] DIA	[#18-#14] AWG	63097-4
4 TIN 0.002032 [.000080] MIN	2.29-3.94 [.090-.155] DIA	[#18-#14] AWG	63097-3
-	2.29-3.94 [.090-.155] DIA	[#18-#14] AWG	63097-2
TIN 0.002032 [.000080] MIN	2.29-3.94 [.090-.155] DIA	[#18-#14] AWG	63097-1
FINISH	INSULATION RANGE	WIRE SIZE	PART NO.

THIS DRAWING IS A CONTROLLED DOCUMENT.

DWN JR RUTH 7/28/86
CHK G YETTER 1/15/87
APVD J GILLESPIE 1/15/87

tyco Electronics Tyco Electronics Corporation
Harrisburg, Pa 17105-3608

RECEPTACLE, POSITIVE LOCK, .250 SERIES

SIZE A2 CAGE CODE 00779 DRAWING NO C=63097 RESTRICTED TO -

MATERIAL H06 BRASS FINISH SEE TABLE

WEIGHT -

CUSTOMER DRAWING SCALE 5:1 SHEET 1 OF 1 REV AE